

(21) Application No 0024464.0  
(22) Date of Filing 05.10.2000  
(30) Priority Data  
(31) 9923400 (32) 05.10.1999 (33) GB

(71) Applicant(s)  
**SMS Technologies Limited**  
(Incorporated in the United Kingdom)  
Elizabeth Way, HARLOW, Essex, CM19 5TL,  
United Kingdom

(72) Inventor(s)  
Kevin Westhead  
Alan Wenman  
Peter Parnell

(51) INT CL<sup>7</sup>  
A61B 5/103  
(52) UK CL (Edition S )  
G1N NENX N30B N30PX N30S  
(56) Documents Cited  
EP 0637222 A1 US 5916160 A  
(58) Field of Search  
UK CL (Edition S ) G1N NACF NACNH NENX  
INT CL<sup>7</sup> A61B 5/103  
ONLINE: WPI EPODOC JAPIO

(74) Agent and/or Address for Service  
Sanderson & Co  
34 East Stockwell Street, COLCHESTER, Essex,  
CO1 1ST, United Kingdom

(54) Abstract Title  
**Balance performance monitoring during the transition between sitting and standing positions**

(57) An apparatus for and a method of monitoring the balance performance of a patient utilises a foot-plate 10 upon which a patient 12 places his feet 13 and a seat 14 upon which the patient may sit. Each of the foot-plate 10 and seat 14 have associated load-determining cells whereby the changing loads imparted to the foot-plate and the seat by a patient as he moves either from sitting to standing or vice versa may be determined. The determined loads are supplied to an analyser, which displays the balance performance to the patient 12, essentially in real time as the patient moves between the sitting and standing positions. Handles 20 may be provided to assist the patient in changing his position, in which case the handles 20 may also be provided with load-determining cells, the outputs from which are also supplied to the analyser.

FIG.6

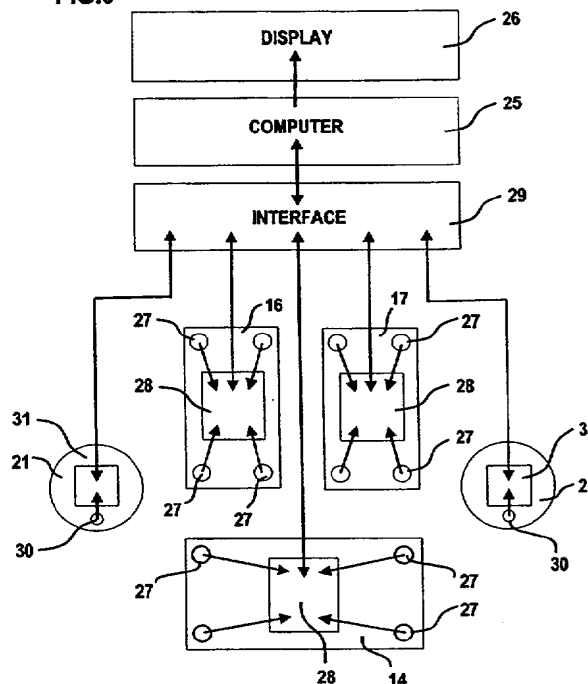

FIG.1

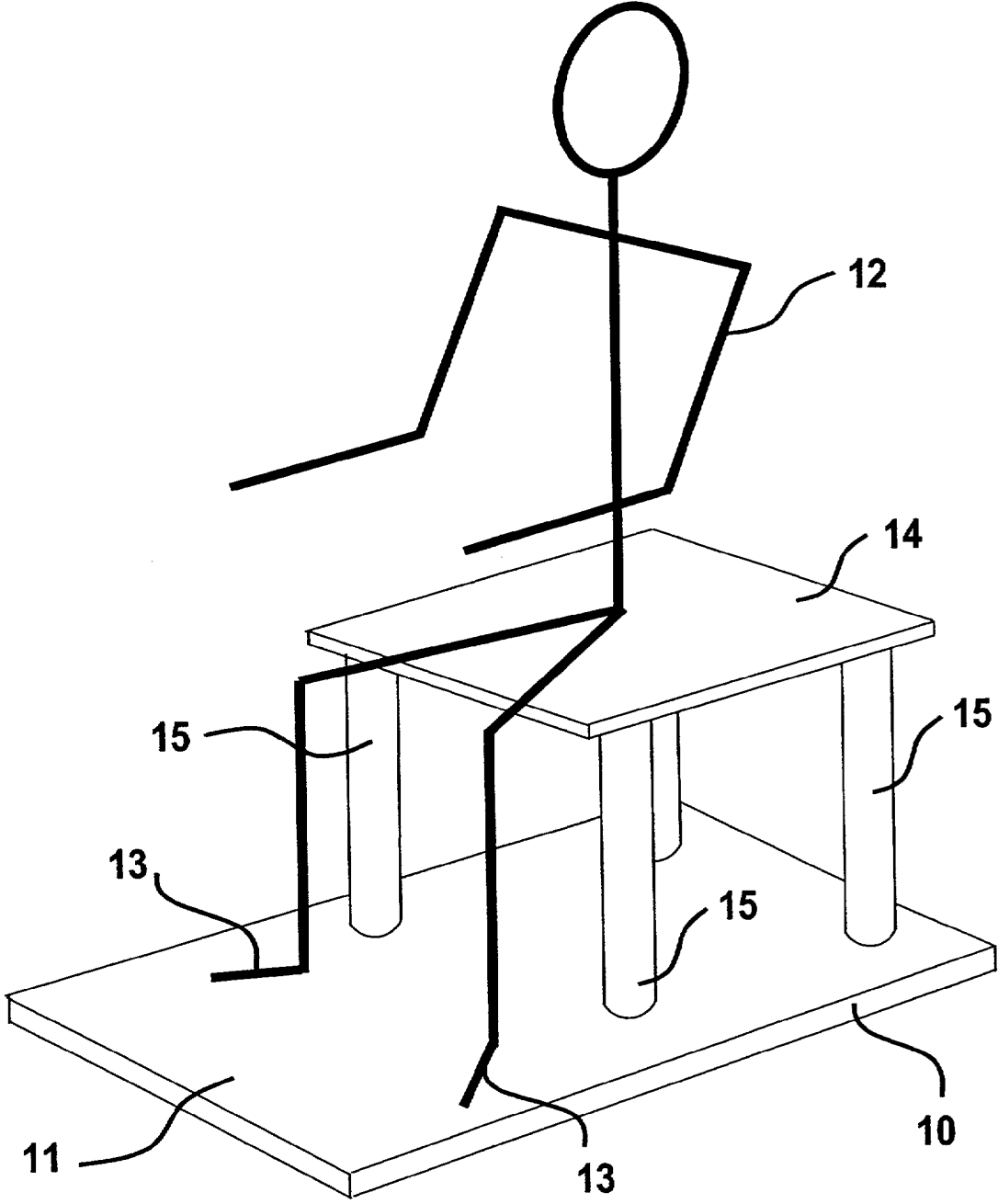

FIG. 2

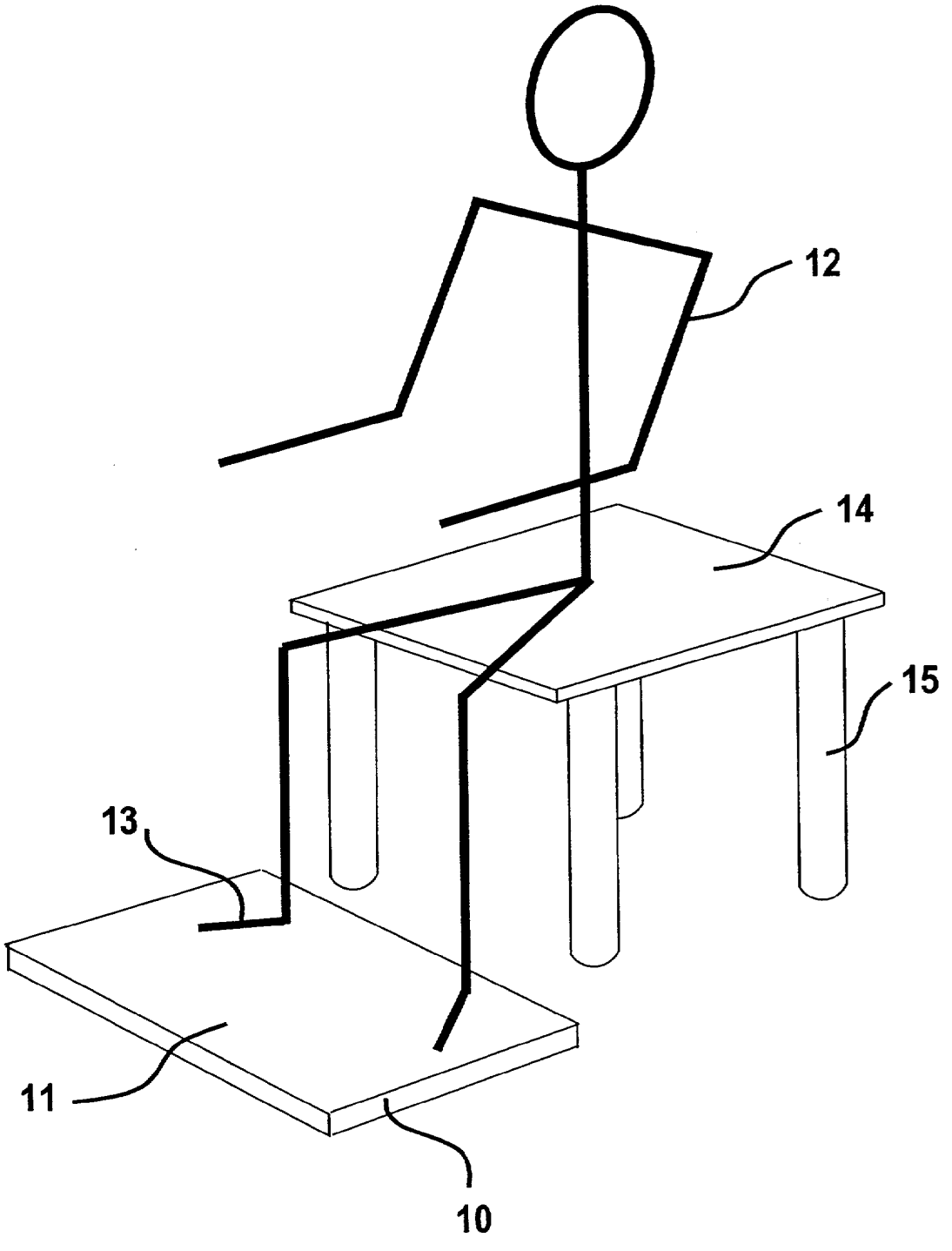

FIG.3

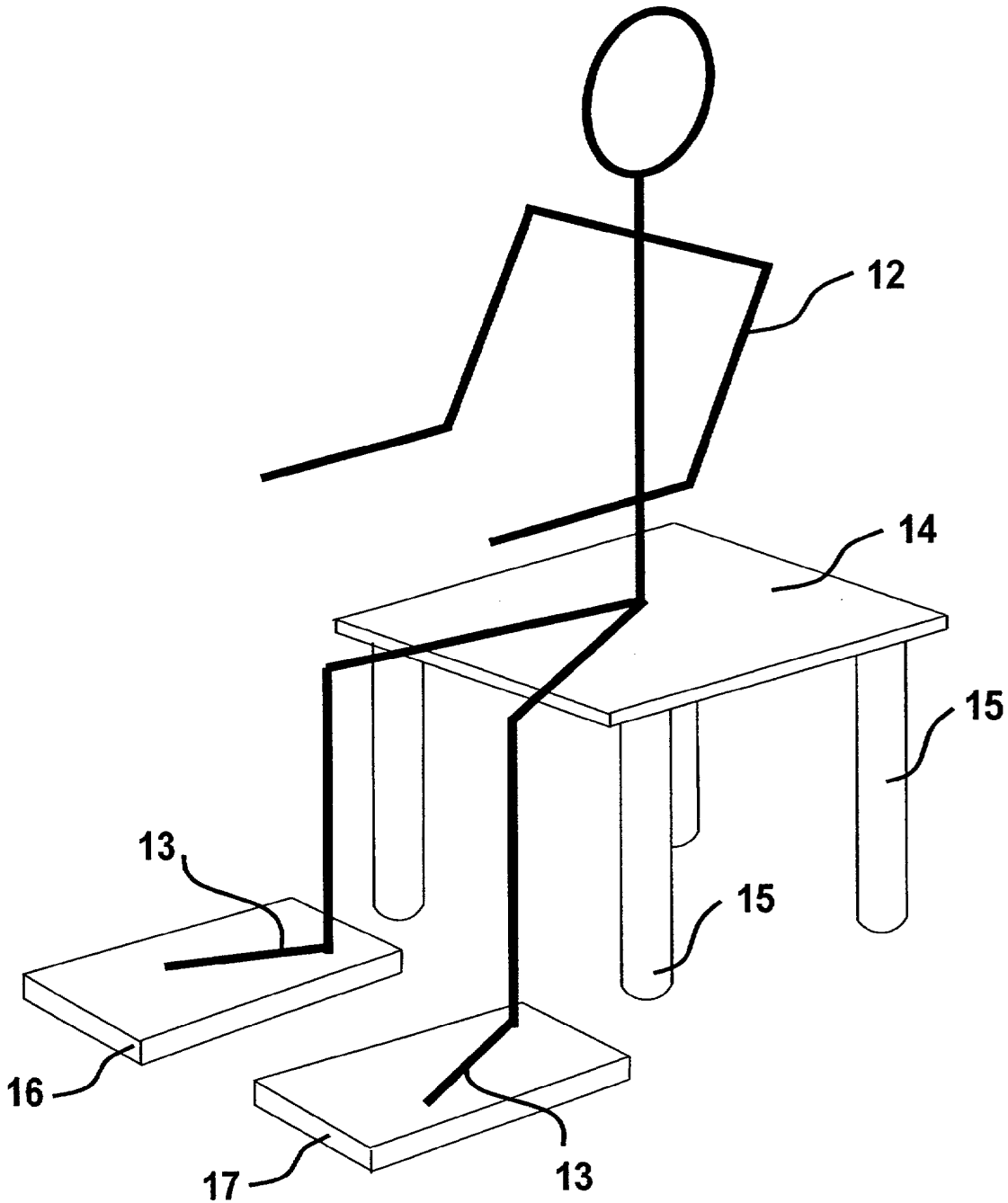

FIG.4

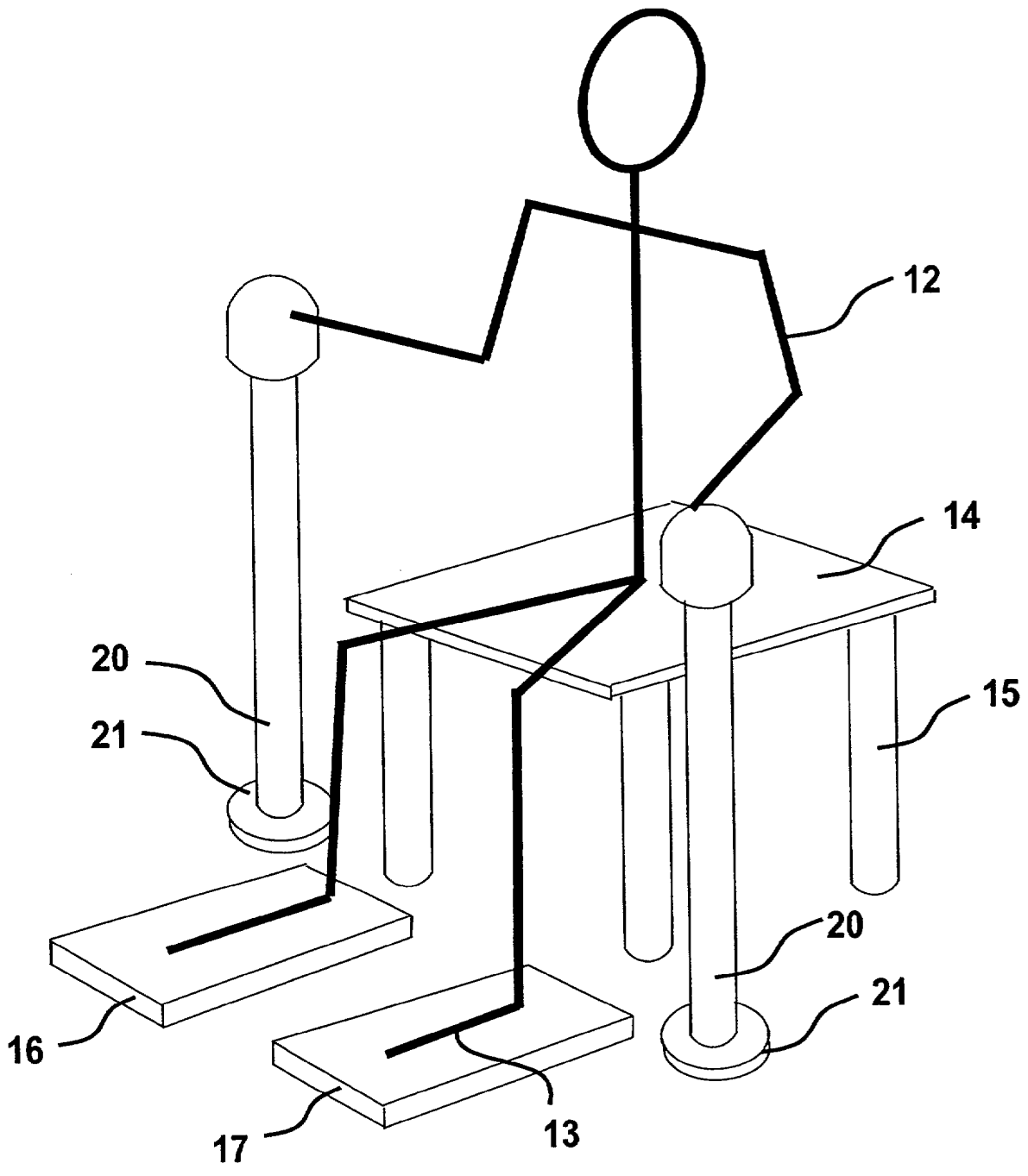

FIG.5

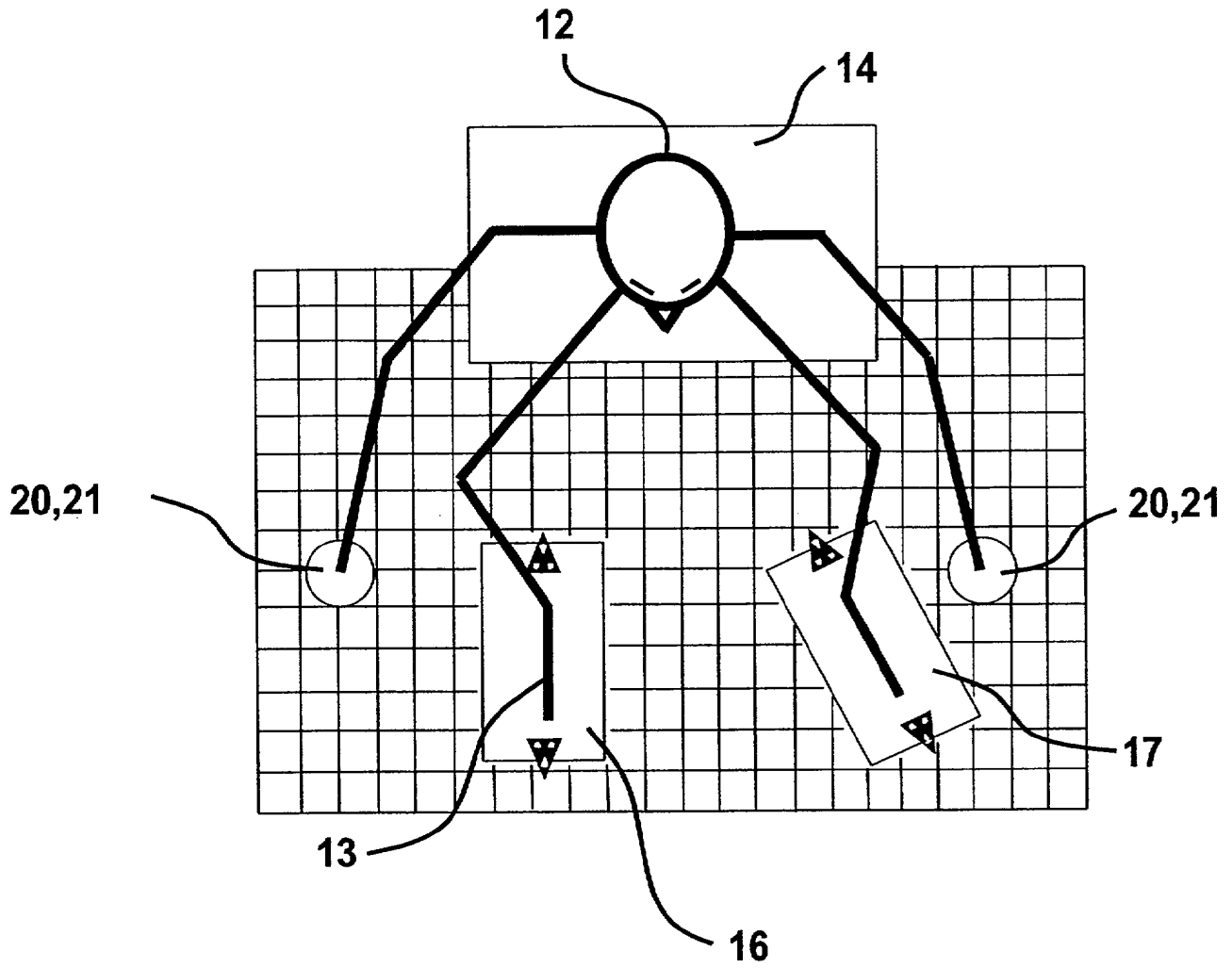

FIG. 6

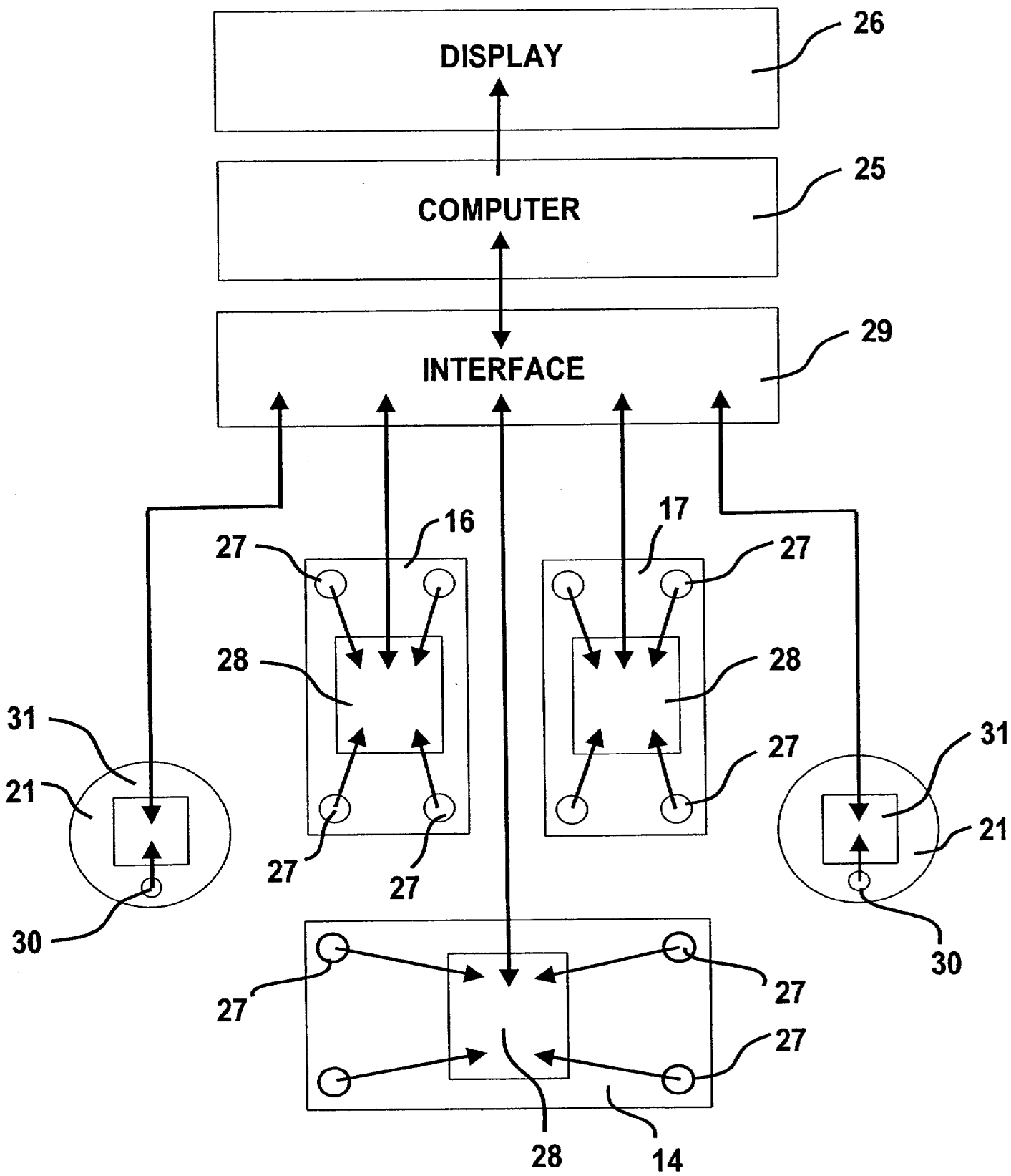
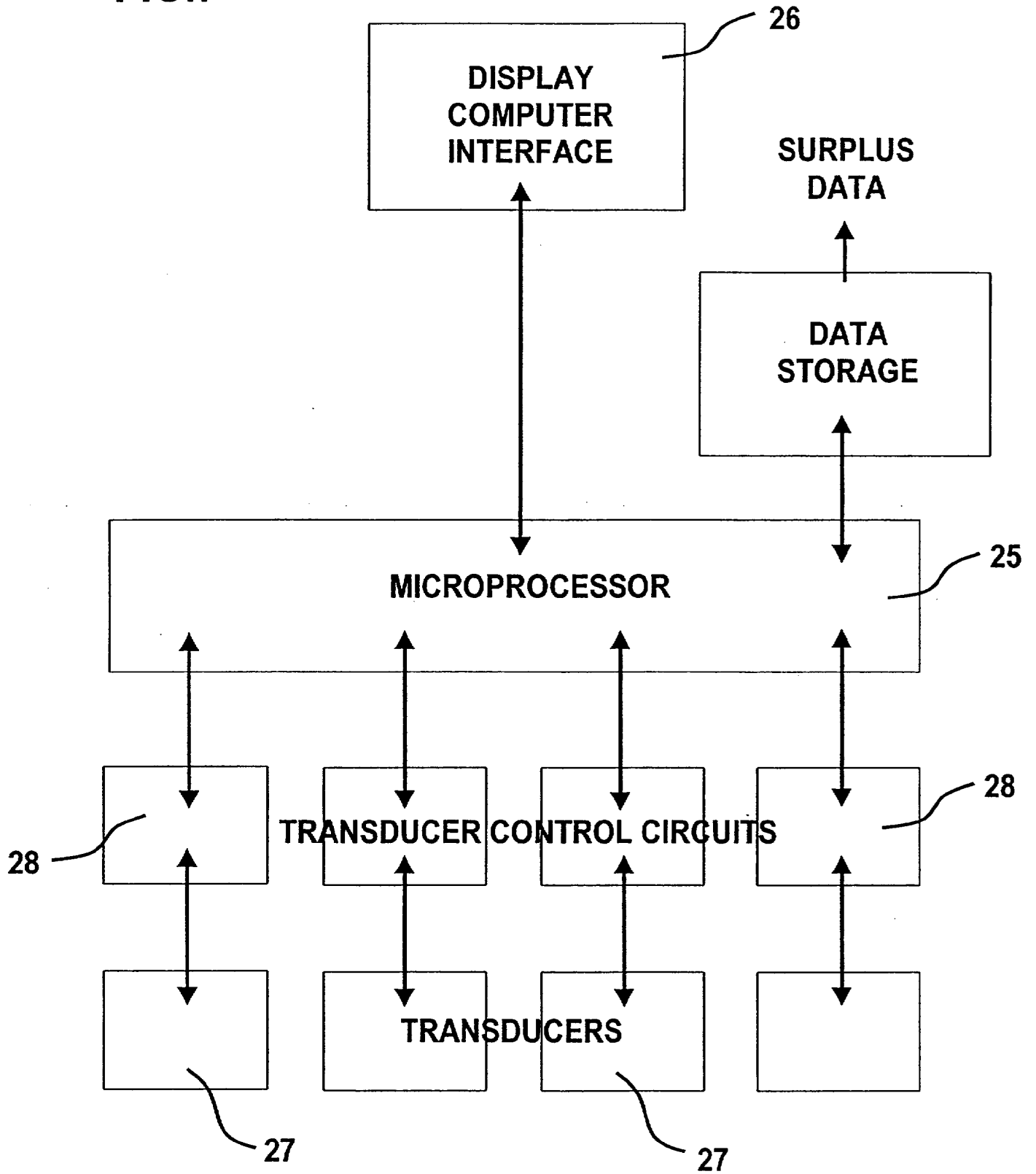

FIG.7





## BALANCE MONITORING

This invention relates to apparatus for monitoring the balance performance of a human user (hereinafter for convenience referred to as a "patient") and also to a method of monitoring a patient's balance performance.

5           Following various medical problems, such as a stroke or post-injury trauma, a person's balance performance may be adversely affected. It can take a relatively long time before such a patient may be able to stand safely without requiring some other support, such as a walking stick. There is thus a need to provide equipment able to assist with and accelerate a patient's  
10           rehabilitation following the on-set of a medical problem.

          It has been established that the balance performance of a standing human (patient) can be improved by providing the patient with a graphical display showing, essentially in real time, his balance performance. In effect, a closed loop feedback system can be established, which allows the patient to  
15           see how his balance performance is deviating from the ideal, so enabling him to make conscious corrections. By using such a system, it is found that eventually the patient is likely to make the required corrections sub-consciously.

          In order to monitor the balance performance of a patient, it is known to provide a pair of foot-plates upon which the patient stands, and to determine  
20           the loads imparted to the foot-plates. The determined loads can be analysed to drive a graphical display, disposed in the patient's field of view. Such equipment can be further improved as described in our prior European Patent No. 0 637 222, by having each foot-plate determine the loads imparted thereto  
25           along two axes substantially at right angles and with one of those axes extending along the length of the patient's foot.

Following extended research into patients suffering from strokes or other post-injury trauma, it has been determined that one of the critical stages in recovery and the return of independent living is the ability to achieve an unaided transition between seated and standing positions, and to a lesser extent between standing and seated positions. That research has determined that the use of a closed loop feedback system providing information to the patient about the position of, or movement of, his centre of balance during the transition can assist the patient in successfully achieving the transition, so as no longer to require external aids.

In view of the above, one aspect of the present invention provides apparatus for monitoring the balance performance of a patient, which apparatus comprises a foot-plate upon which the patient places his feet, a seat upon which a patient may sit, respective load-determining means associated with the foot-plate and the seat to determine the loads imparted to the foot-plate and the seat by a patient as the patient moves in either sense between sitting and standing positions, and balance analysis means arranged to receive outputs from the load-determining means and to display to the patient his balance performance, essentially in real time.

According to a second aspect of this invention, there is provided a method of monitoring the balance performance of a patient, comprising seating the patient on a seat and placing the patient's feet on a foot-plate, the seat and foot-plate being provided with respective load-determining means, having the patient move between seated and standing positions and monitoring the load-determining means during that transition, analysing the monitored loads essentially in real time and determining the shift in the centre of balance of the

patient during the transition, and displaying said shift to the patient in a graphical manner as the transition takes place.

The seat and foot-plate could be integrated into a single unit furnished with appropriate load-determining means, in order to allow an assessment of the changing loads imparted to the seat and the foot-plate as the patient transitions between the seated and standing positions. Suitable analysis of those changing loads then permits the driving of the real time graphical display showing the patient how his centre of balance shifts at least in the front-to-back directions during the transition - and the patient may strive to retain that centre of balance within certain defined regions which enable a successful, unaided transition to be accomplished.

An alternative form of the apparatus has a seat physically detached from the foot-plate, whereby those components may be relatively adjusted in order to suit different patients and their physical build. In this case, the foot-plate may be divided into two separate sub-plates, one for each foot respectively, whereby the load imparted to each sub-plate, by each foot respectively, may separately be determined. In a further enhancement, the loads on each foot-plate may be determined about two axes mutually at right angles and with one axis extending substantially along the length of a user's foot, in a generally similar manner to that described in EP-B-0 637 222 aforesaid. Also, the seat may be configured to determine the loads thereon, about two axes mutually at right angles.

At least one of the load-determining means associated with the foot-plate (and each of the sub-plates, if appropriate) and the seat may be arranged to determine the loads in a lateral direction and applied thereto by a patient, with respect to the direction in which the patient is facing - i.e. transversely

(laterally) of the patient. In this way, the graphical display may show not only the shifting of the patient's centre of balance in the front to back direction, as the patient performs the transition from sitting to standing positions, or vice versa, but also the position of the centre of balance laterally of the body. Thus, with this closed loop feedback system, the patient may strive to keep the centre of balance well within the width of his body, so reducing the likelihood of loss of balance in a transverse direction.

The apparatus of this invention may be made suitable for use by patients with even more seriously impaired balance performances by providing at least one, and preferably two, handle assemblies which may be grasped by a patient and used to assist the transition from sitting to standing positions. The or each such handle assembly should also be provided with at least one load sensor to determine the load applied thereto by the patient, and which load is taken into account by the balance analysis means, in driving the graphical display. A simpler form of the device may have the handles simply connected to the foot-plate, or the sub-plates, if appropriate, whereby the load imparted to the handles will be taken into account by the load-determining means associated with the foot-plate, or sub-plates. The handle assemblies may be arranged to determine the vertical and horizontal loads applied thereto, as a patient moves between the sitting and standing positions. Only the vertical load would ordinarily be used for calculating the patient's centre of balance, but the horizontal load will indicate the amount of force applied by a patient in pulling himself up.

An improved assessment of the balance performance can be obtained if the load analysis means also takes into account the relative positions of the

seat, foot-plate (or sub-plates) and handles (if provided). In this way, the shifting of the centre of balance during a patient transitioning between sitting and standing positions can better be shown, and moreover can display the velocity of the movement of the centre of balance, as well as the actual position  
5 of that centre of balance.

A preferred form of the apparatus samples the outputs from the load-determining means and analyses the balance performance from the sampled outputs, the display of the balance performance being up-dated at a relatively low rate. However, the analysis means preferably permits the storage of the  
10 sampled outputs, whereby detailed analysis may be undertaken, for example by a clinician, at some time subsequently by loading the stored data. In this way, with the analysis taking place not in real time, the movement of the centre of balance can more accurately be assessed, using all the stored data, or more of the data than was employed for the real-time display of the balance  
15 performance.

By way of example only, the invention will now be described in greater detail, and certain specific embodiments thereof given, reference being made to the accompanying drawings, in which:-

Figure 1 illustrates a simple system of this invention and having an  
20 integrated foot platform and seat;

Figure 2 illustrates a modified form of the system of Figure 1, where the foot platform and seat are separate;

Figure 3 illustrates a further modified form, where the foot platform is divided into two separate sub-plates;

Figure 4 illustrates a system similar to that of Figure 3, but having two hand supports;

Figure 5 shows the system of Figure 4, but arranged on a floor grid to facilitate the determining of the relative positions of the component parts of the system;

Figure 6 is a block diagram showing the system of Figure 5; and

Figure 7 is a block diagram showing the operation of a typical foot-plate.

In the following description of the drawings, like reference characters are used to show like components. Those components will not be described in detail again, following the first description thereof.

Referring initially to Figure 1, there is shown an integrated force platform for use in performing the method of this invention, this platform having a base 10 defining a front area 11 on which a patient shown diagrammatically at 12 may place his feet 13. The base 10 supports a seat 14 on four pillars 15 mounted on the base. The base is provided internally with appropriate load sensors (not shown) for determining the loads imparted to the front area 11 by the patient's feet 13 and to the seat, through the pillars 15.

A graphical display (not shown) is arranged in front of the patient 12, so that it is easily visible by him, whether the patient is seated as shown, or is standing on the front area 11. A processing unit serves to analyse the forces determined by the sensors within the base 10, so as to evaluate the approximate position of the centre of balance of the patient, and to drive the graphical display dependent thereon. Thus, the patient may see, essentially in real time, the position of and movement of his centre of balance, whether

seated, standing or undertaking a transition between seated and standing positions, or vice versa.

Figure 2 shows an arrangement similar to that of Figure 1, but the pillars 15 are not mounted on the base 10; rather, the base 10 is separate from the seat 14 so that these components may be relatively adjusted. In this case, load sensors may be provided within the pillars 15, at the top of each pillar for mounting the seat, or within the seat itself, so that the load imparted to the seat can be determined thereby.

Figure 3 differs from the arrangement of Figure 2 in that the base 10 is divided into two separate sub-plates 16 and 17, one for each foot 13 of the patient. This permits the accommodation of the wider range of patients, including those who may have difficulties placing their feet sufficiently close together or symmetrically disposed, since the sub-plates may be appropriately positioned for the patient's feet. Though each sub-plate 16, 17 may simply determine the total load imparted thereto, it may be advantageous to enhance the system by having each foot-plate arranged to determine the load imparted along two axes mutually at right angles, with one axis extending along the length of the sub-plate, which should of course be substantially aligned with patient's foot. This permits a better assessment of how the patient's centre of balance is shifting in the lateral direction, as the shift is occurring, as well as a better assessment in the anterior/posterior direction.

Figure 4 shows a yet further modification, where separate handles 20 are provided for the patient, one for each hand. Though those handles could be integrated for example one with each sub-plate 16, 17 respectively, in this example the handles are completely separate and each is provided with a base

21. Each handle has a respective load sensor (not shown), typically at the top of the column. The processing unit may take into account the load imparted to each such handle 20 and modify the graphical display as appropriate, after taking that load into account.

5            Each handle may be provided with a second sensor, so that the loads imparted to the handle in the vertical and horizontal directions may be determined. The horizontal force is not used to calculate the centre of balance, but is an enhancement to indicate the force the patient is using to pull himself forward. The height of both the seat and the handles can be adjusted to  
10 accommodate the broadest possible range of patients.

          Figure 5 shows the components of Figure 4 provided on a grid marked on the floor. This grid permits easy determination of the co-ordinates of each component with reference to a given datum - for example, the top left hand corner of the grid as shown in Figure 5, to permit the entry of the relative  
15 positions into the processing unit. Such an arrangement has the advantage that the processing unit may better determine the movement of the centre of balance and the likelihood of that centre of balance falling outside the area of support of the patient, as defined by the patient's feet and possibly also the buttocks and hands.

20            Figures 6 and 7 diagrammatically illustrate the connection of the various components of Figure 5 to a processing unit 25 which drives a graphical display 26. Each sub-plate 16, 17 and the seat 14 is provided with four load sensors 27, disposed one adjacent each corner of the respective component. These load sensors may take any suitable form, such as a load cell, a Piezo-electric  
25 device, or other load transducer. The outputs from the four sensors are



collected by a respective electronic circuit 28 which in turn feeds an output to a computer interface circuit 29. Each handle 20 has at least one load sensor 30 (but possibly two sensors, as discussed above) connected to a suitable circuit 31 provided within the assembly of the handle and base 21 and which feeds an output to the interface circuit 29. To ensure synchronisation of the data from all of the sensors, the interface sends a single signal to all of the circuits 28, 31 to capture data from the sensors; selected captured (sampled) data is amplified and converted to a digital signal which is then processed by the computer 25. Typically, the data is sampled at a frequency between 100 and 1000 times per second.

To give an effective display to a patient of his balance performance, the display 26 does not need to be up-dated at the same rate as the data is sampled. In any event, the processing of the sampled data to drive the display with the position of the patient's centre of balance takes a significant time and using current technology it would be very difficult to perform at the sampling rate. Consequently, the data sampled at the relatively high rate is supplied to a rolling buffer and the data is extracted from that buffer by the computer, for detailed analysis when requested by the operator.

The electronic circuits 28, 31 incorporated within the seat, foot-plate and handles may themselves include buffers which may be interrogated by the interface circuit when required. For example, when a specific activity is to be undertaken, the interface circuit may initialise the buffers at the start of the activity, to permit the storage of data for a period of time following initialisation but without permitting over-writing of specified sections of the buffer, thus retaining an historic element of data from before the trigger point. Then, the

computer may sample that stored data for detailed analysis, quite apart from the real time analysis described above.

The data supplied to the computer may include an identifying code to permit the data to be associated with the particular sensor producing that data.

- 5 The programme running within the computer may then compute the element of the centre of balance for each of the multi-transducer force plates, and then compute the apparent position of the overall centre of balance, taking into account the relative positions of the force plates, provided that those relative positions have previously been entered as described with reference to Figure 5.
- 10 In this way, the overall position and movement of the centre of balance, as well as elements of the centre of balance can be displayed as specified by the operator for the patient, as bio-feedback on the computer display.

- It will be appreciated that the apparatus and methods described above may be employed other than strictly for clinical reasons. For example, the
- 15 equipment may be employed whilst a person performs other activities, associated for example with a working environment, various sports and so on.

## CLAIMS

1. Apparatus for monitoring the balance performance of a patient, comprising a foot-plate upon which the patient places his feet, a seat upon which a patient may sit, respective load-determining means associated with the  
5 foot-plate and the seat to determine the loads imparted to the foot-plate and the seat by a patient as the patient moves in either sense between sitting and standing positions, and balance analysis means arranged to receive outputs from the load-determining means and to display to the patient his balance performance, essentially in real time.
- 10 2. Apparatus as claimed in claim 1, wherein the seat and the foot-plate are integrated into a single unit furnished with load-determining means to permit the display of the shift in the centre of balance of a patient during movement between sitting and standing positions.
3. Apparatus as claimed in claim 1, wherein the foot-plate and the seat are  
15 physically detached to permit relative adjustment therebetween, to suit different patients.
4. Apparatus as claimed in claim 3, wherein the foot-plate is divided into two sub-plates, respectively one for each foot and each having a respective load-determining means.
- 20 5. Apparatus as claimed in any of the preceding claims, wherein the load-determining means associated with at least one of the foot-plate and the seat is arranged to determine the loads applied thereto by a patient in a direction extending transversely (laterally) with respect to the direction in which the patient is facing.

6. Apparatus as claimed in any of the preceding claims, wherein the seat is arranged to determine the loads applied thereto by a patient about two axes mutually at right angles.

7. Apparatus as claimed in any of the preceding claims, wherein the  
5 apparatus further includes at least one handle assembly for grasping by a patient moving between sitting and standing positions, which handle assembly includes a load-sensor to determine the load imparted to the handle by the patient and to supply the determined load to the balance analysis means.

8. Apparatus as claimed in claim 7, wherein the apparatus includes a pair  
10 of handle assemblies for use by a patient moving between sitting and standing positions, each of which handle assemblies includes a respective load-sensor to determine the load imparted thereto by the patient and to supply the determined load to the balance analysis means.

9. Apparatus as claimed in claim 8, wherein each handle assembly has a  
15 load sensor to determine the load applied to the assembly as a patient pulls himself up from a sitting position.

10. Apparatus as claimed in any of the preceding claims, wherein means are provided to determine the relative positions of the seat, foot-plate and handles (if provided), and the balance analysis means is arranged to take into account  
20 said relative positions in determining a patient's balance performance.

11. Apparatus as claimed in any of the preceding claims, wherein balance performance information is presented to a patient in a graphical form on a display device, essentially in real time as the patient moves.

12. Apparatus as claimed in any of the preceding claims, wherein the  
25 balance analysis means samples outputs from the load-determining means at a

relatively high rate and analyses the balance performance from the sampled outputs, and updates the display of the performance at a relatively low rate.

13. Apparatus as claimed in any of the preceding claims, wherein the balance analysis means stores the analysed balance performance for  
5 subsequent display or printing, or further processing.

14. Apparatus for monitoring the balance performance of a patient and substantially as hereinbefore described with reference to and as illustrated in the accompanying drawings.

15. A method of monitoring the balance performance of a patient,  
10 comprising seating the patient on a seat and placing the patient's feet on a foot-plate, the seat and foot-plate being provided with respective load-determining means, having the patient move between seated and standing positions and monitoring the load-determining means during that transition, analysing the monitored loads essentially in real time and determining the shift in the centre  
15 of balance of the patient during the transition, and displaying said shift to the patient in as the transition takes place.

16. A method as claimed in claim 15, wherein the shift in the centre of balance is displayed in a graphical format to the patient, relative to an acceptable performance.

20 17. A method as claimed in claim 15 or claim 16, wherein the outputs from the load-determining means are sampled at a relatively high rate, and selected sampled outputs are employed for determining the balance performance of the patient, for display.

18. A method as claimed in claim 17, wherein the sampled outputs are  
25 stored for subsequent analysis of the balance performance of the patient.

19. A method of monitoring the balance performance of a patient and substantially as hereinbefore described with reference to the accompanying drawings.



INVESTOR IN PEOPLE

Application No: GB 0024464.0 15 Examiner: Brian Mc Cartan  
 Claims searched: 1 - 19 Date of search: 23 April 2001

**Patents Act 1977**  
**Search Report under Section 17**

**Databases searched:**

UK Patent Office collections, including GB, EP, WO & US patent specifications, in:  
 UK Cl (Ed.S): G1N (NACF, NACNH, NENX)  
 Int Cl (Ed.7): A61B 5/103  
 Other: Online: WPI, EPODOC, JAPIO

**Documents considered to be relevant:**

Category	Identity of document and relevant passage	Relevant to claims
Y	EP 0637222 A1 DAUGHTERY See the description of figures 1 & 5	1 - 19
Y	US 5916160 A ARCAN See the description of figure 8	1 - 19

X	Document indicating lack of novelty or inventive step	A	Document indicating technological background and/or state of the art.
Y	Document indicating lack of inventive step if combined with one or more other documents of same category.	P	Document published on or after the declared priority date but before the filing date of this invention.
&	Member of the same patent family	E	Patent document published on or after, but with priority date earlier than, the filing date of this application.